



K-109



AQM-37A JayHawk

Specifications:

Length: 30.75"
Diameter 2.6
Weight: 19oz
Recovery: 30" Nylon Chute
Motor Mount: 29mm
Fins: 4 - 1/8" Plywood
CG: 19" from nose tip

Recommended Motors:

Single Use	RMS
F20W-4 950'	F40W-7 1090'
F23FJ-4 820'	
F25W-6 1100'	
F26FJ-6 960'	

Parts List

1. (1) Plastic nose cone
2. (1) Custom balsa tail cone
3. (1) pre-slotted body tube
4. (1) Centering ring
5. (1) 29mm motor tube
6. (2) laser-cut fins
7. (2) laser-cut winglets
8. (2) laser-cut canards
9. (1) 1/8" dowel - 12" long
10. (1) Kevlar® shock cord section
11. (1) Nylon shock cord section
12. (1) 9"x9" flameproof chute protector
13. (1) 30" Nylon chute
14. (2) 1/4" launch lugs
15. (1) Water slide decals

Required to complete: 5 minute epoxy, 120/220 sandpaper, masking tape, finishing filler/paint, lead shot for nose weight.



Please make sure you read all directions and understand how to assemble your model before you start construction. It is also a good idea to test fit each part before assembly – some manufacturing tolerances may require light sanding before final assembly.

Laser cut parts will exhibit varying amounts of charring on the edges depending on the density of the plywood. The charred edges do not interfere with bonding and do not need to be cleaned before assembly. In most cases the charring will be cleaned up during sanding for finishing and painting.

Step 1 – Motor Mount Assembly

Test fit the tail cone into the aft end of the body tube. Make sure that the tail cone shoulder does not interfere with the fin slot. If it does, sand the shoulder to the correct length (the nominal length of the shoulder should be 0.5"). Next, Test fit the tail cone and centering ring over the motor mount tube and sand if necessary. The centering ring should have a snug fit but loose enough to move the ring over the motor tube without deforming it. Also test fit the centering ring in the body tube and sand if necessary.

Spread some epoxy on the outside of one end of the motor tube and slide the tail cone in place so the motor tube is flush with the aft end of the tail cone. Make sure you clean the motor tube of any epoxy so as not to interfere with the fin tangs later.

After the tail cone is dry, make a mark 3/8" from the other end of the motor tube. Spread some epoxy on the motor tube and slide the forward ring (with the notch) until it aligns with the mark.

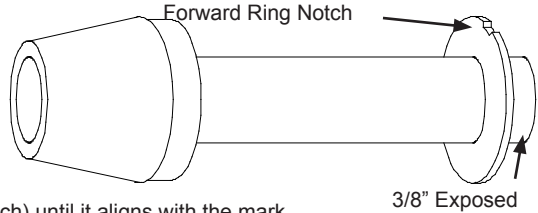

Step 2 – Shock Cord Attachment

The shock cord in this kit consists of a shorter section of Kevlar and a longer section of nylon cording. The two sections should be tied together using a single overhand, ring bend or double fisherman's knot. The Kevlar section will be attached to the motor mount and the nylon section will be attached to the nose cone.

Wrap the end of the Kevlar shock cord around the forward end of the motor tube and tie a square knot or bowline knot near the notch in the forward centering ring. Apply some epoxy to the knot to make sure it doesn't come loose later.

Make sure the Kevlar loop is seated against the forward centering ring so that it will not interfere with the fin tangs later. You can tack with epoxy or CA to hold in place.

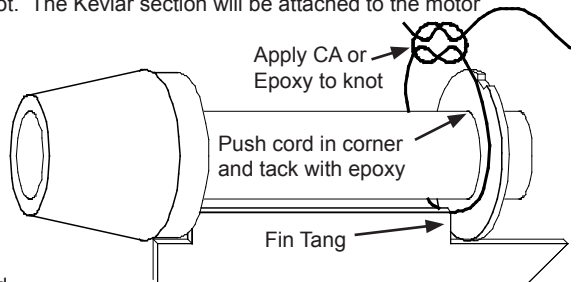

Step 3 – Insert Motor Tube Assembly into Body Tube

Wrap the shock chord into a small bundle and stuff it inside the motor tube for this next step. Make sure the cord passes over the notch in the forward centering ring. Test fit the motor tube assembly into the body tube to ensure a snug fit. Sand the centering ring if necessary. When you are satisfied with the fit, spread some epoxy on the inside of the body tube and slide the forward centering ring of the motor assembly into the body tube. Spread some more epoxy on the inside edge of the body tube before sliding the tail cone into the body tube. Continue sliding the assembly inside the body tube until the tail cone

is seated into the body tube. It's a good idea to test fit a fin in each slot here before the epoxy sets. Hold the body tube with the motor tube assembly down until the epoxy sets. Make sure the weight of the motor assembly doesn't cause it to slide out of alignment.

Using a door jam or small section of angle stock, pencil a line halfway between two of the fins that extends from the front to the back of the body tube. This line will be used later to align the launch lugs.

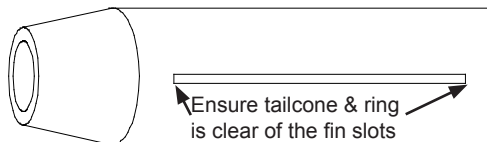

Using the same method, pencil a line that extends from each of the fin slots to the forward end of the body tube. This will help you align the long forward section of the fins.

Step 4 – Fin Assembly

Special Note: The Jay Hawk is notorious for breaking off winglets on rough windy landings. Two schools of thought can be used here; The first is to lightly tack the winglets to the fins and assume the winglet will break off frequently. If it is tacked lightly, no damage should occur and the winglet can be re-tacked to the fin over and over again. The second school of thought is to attach the winglet securely and fly only in low wind situations hoping a rough landing will not snap the winglet off.

Start by testing the fit of the winglet onto the tip of the fin. Sand the winglet slot and/or fin tip if necessary. When you are satisfied with the fit, apply some epoxy to the fin tip and attach the winglet. Ensure the winglet is 90 degrees to the fin. Continue checking the alignment until the epoxy sets.

Test fit each of the fins into the pre cut fin slots. The fin should seat firmly against the motor tube - sand each fin if necessary. When you are satisfied with the fit, apply some epoxy to the end of the fin tang that will contact the motor tube as well as the fin root that will contact the body tube. Also, spread a thin layer of epoxy on each side of the fin tang.

Slide the fin into place and check the alignment. Carefully align the long forward section of the fin with your fin alignment marks. Secure the forward section of the fin with masking tape against the body tube. Clean any excess epoxy from around the fin joint. Continue rechecking the fin alignment until you are sure the epoxy has set. Repeat for the remaining fins.

Next, apply epoxy fillets to both sides of each fin. Carefully smooth the epoxy fillets with your finger before the epoxy sets. Allow each fillet to set before rotating the airframe for the next fillet.

Step 5 – Launch Lug Attachment

Mark the CG point along the launch lug line you made in the previous step. Make sure you measure the CG point from the tip of the nose cone and NOT the end of the body tube. Apply a small amount of epoxy on the launch lug line about $\frac{3}{4}$ " long on the CG mark. Press one of the launch lugs into the epoxy and ensure that it is aligned with the launch lug line previously drawn on the body tube. You can site down the tube and look through the launch lug to make sure it is straight.

Similarly epoxy the second launch lug about $\frac{1}{2}$ " from the aft end of the body tube. Site down both launch lugs and make sure they are both aligned. If you have a $\frac{1}{4}$ " launch rod, you can use this to ensure that both lugs are aligned properly.

Step 6 – Nose Cone Assembly

Start by marking the nose cone with the two canard fin alignment lines 180 degrees apart. The leading edge of the canard is the longer straight edge. The curved edge will attach to the nose cone. Mark the alignment lines at 2.5" and 3.25" from the aft end of the nose cone where it meets the shoulder. **IMPORTANT:** make sure you don't measure from the aft end of the shoulder as this will make the canards too far back. Do this for both sides of the nose cone. Next, drill four 1/8" diameter holes at each of these marks. This will allow the 1/8" dowels to pass through the nose cone to attach the canards.

Cut two 4" length of the 1/8" dowels. Test fit these dowels in the canard slots. Sand the slot or dowel as necessary for a good fit. Next, pass the dowels through the nose cone as shown in the figure. Test fit the canards as shown over the dowels and make sure the root edge of the canard seats against the nose cone. Shorten the dowels if necessary. When you are satisfied with the fit, mix some epoxy and attach the canards along the alignment mark with the dowels centered in the slot as shown. You can use masking tape on both sides of the canard while the epoxy sets if you wish to hold them in place. Make sure both fins are 180 degrees apart and the root is seated firmly against the nose cone while the epoxy cures. After the epoxy cures, you can apply fillets to fill any space between the canard and the nose cone. Note: the epoxy will not stick very well to the nose cone. The dowel is the main structural part that will hold the fin in place. The epoxy fillets only serve to fill any gaps for painting.

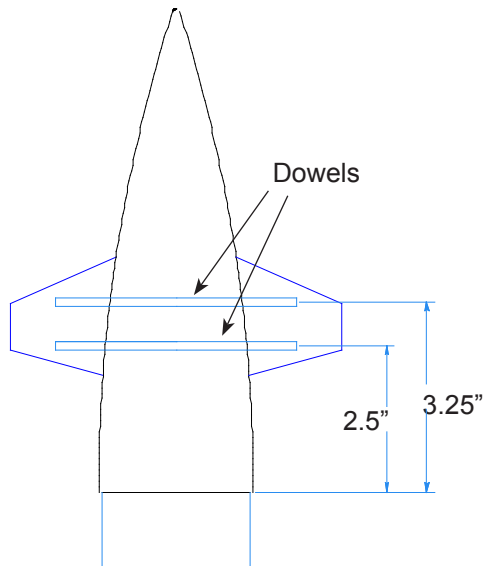

At this point, pack the chute and assemble the rocket. Insert the largest motor you intend to fly (or simulate the weight with an substitute). Ensure the CG is forward of the recommended CG. The CG is measured from the tip of the nose cone. If the CG is behind the specified point, add weight inside the nose cone by pouring lead shot into the nose cone tip and adding some epoxy. **IMPORTANT: Screw in a screw through the plastic nose cone into the lead to hold it in place. Grind or cut off the screw head before filling and applying the nose cone finish. The epoxy will not stick to the inside of the nose cone and if you do not anchor with a screw, the liftoff force will cause the weight to become dislodged causing an unstable model.** You can also place the lead in the base of the nose cone so that it cannot become dislodged during liftoff, but you will have to use more weight.

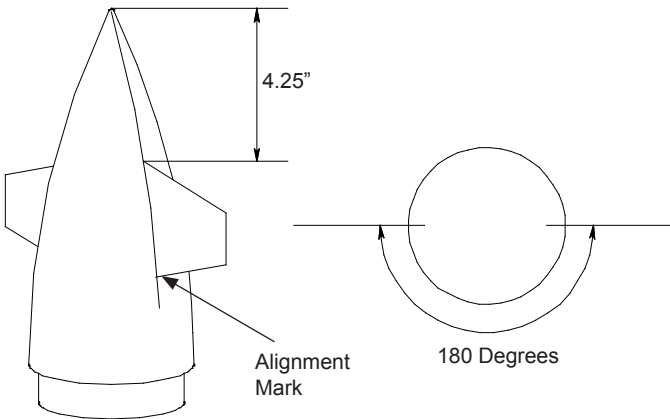

Painting a plastic nose cone requires special preparation because the plastic is very slippery and doesn't take paint very well.

Several of the spray paint manufacturers have plastic paint out now in various colors. If you can find plastic white primer this is best to use to get your nose cone ready for it's final color.

Start by sanding the plastic surface with 320 sandpaper. Be careful not to scratch the surface too much, you just want to get a rough finish for the primer to stick too. You can also fill and sand any gaps in the plywood and dowel joint at this time. Next, apply several coats of the plastic primer. Allow the primer to dry completely before proceeding - most manufacturers suggest 5 days before the primer has properly bonded with the plastic.

After the primer has cured, you can lightly sand the entire surface with 320 sandpaper to remove any scratches in the plastic that might be showing through the primer. Be very careful not to sand through the primer or you will need to start over. Last apply the final color coat to the nose cone. It's recommended that you use the same brand as the primer so you ensure compatibility between the paint. We have found this combination the give the plastic cone a very durable finish.

You can now paint the rest of your model and apply the decals.

Step 7 – Flying Your Model

Attach the end of the shock cord and the parachute to the nose cone. You can also attach the chute protector to the shock cord just below the nose cone. When packing your chute, wrap the chute protector around the chute with the opening in the chute protector facing forward. Always make sure your chute is well protected as the hot ejection motor gasses will melt the nylon chute.

IMPORTANT: always use positive motor retention to secure the motor. Failure to use motor retention will cause the motor to be ejected instead of the parachute making for a dangerous ballistic reentry.

IMPORTANT: some motors do not have a thrust ring that rides against the back of the motor tube. You can construct a thrust ring by wrapping a 1/4" wide strip of masking tape around the aft end of the motor until you have a layer of masking tape approximately the same thickness of the motor tube. Do not fly without a thrust ring as the motor will fly through the rocket causing a dangerously unstable free flying rocket motor.

IMPORTANT: always remember to check your balance point and ensure your CG is ahead of the specified CG point.

IMPORTANT: Always follow the NAR safety code and remember that rockets are not toys and can be dangerous if not prepared and used properly. If you are a beginner, it is a good idea to fly with a club or other group of experienced rocketeers until you have gained some experience.

IMPORTANT: In no event shall Madcow Rocketry be liable for any direct, indirect, punitive, incidental, special consequential damages whatsoever arising out of or connected with the use or misuse of it's products. The buyer assumes all risk and liability resulting from ANY use of any and all products sold by Madcow Rocketry. Your purchase and use of any Madcow Rocketry product constitutes your agreement to and acceptance of these terms. If you do not agree to these terms and conditions, you must return the unused product in resalable condition for a refund or credit.

IMPORTANT: Please contact us via phone or email if you have any questions about constructing or flying your model.

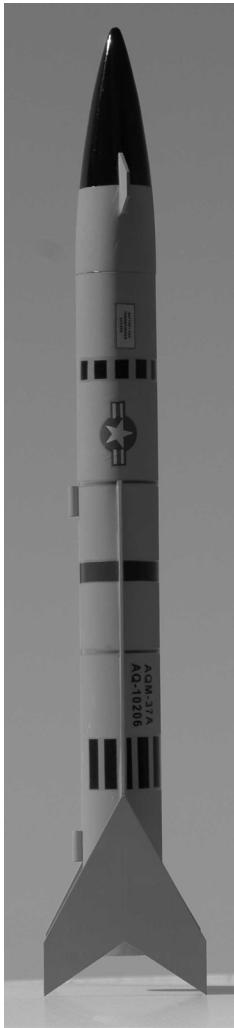



24338 El Toro Rd #E-134
Laguna Woods, CA 92637
949.547.8847
www.madcowrocketry.com
©2006 MadCow Rocketry™