

HONEST JOHN STYLE M31

Specifications:

Length: 38"
Diameter 2.6" (3.5" at Nose)
Weight: 28oz
Recovery: 30" Nylon Chute
Motor Mount: 29mm
Features: Vinyl Decal
Fins: 4, 1/16" G10
Scale: 1:8.5
CG: 29.5" from nose tip

Suggested Motors:

<i>Aerotech</i>		<i>Cesaroni</i>	
F50T-6	600'	F59WT-5	475'
G40W-7	990'	G83BS-7	1140'
G64W-7	1320'	G88SS-7	840'
G77R-7	1150'	G118BS-9	1840'

Parts List

1. (1) Fiberglass nose cone
2. (1) G10 nose cone bulk plate
3. (1) Pre-slotted body tube
4. (2) G10 centering rings
5. (1) 29mm motor tube
6. (4) G10 fins
7. (2) Eyebolt, nut, washer set
8. (1) Nylon shock cord
9. (2) 1/4" launch lugs
10. (2) Launch Lug Spacers
11. (4) Nose cone rocket facade
12. (1) Cut Letter Vinyl decal

Optional Recovery System

1. (1) 9"x9" flameproof chute protector
2. (1) 30" Nylon chute

Required to complete: 5 minute epoxy,
120/220 sandpaper, finishing filler/paint
Rubbing Alcohol for cleaning.

K-115



8 98666 00115 4



Please make sure you read all directions and understand how to assemble your model before you start construction. It is also a good idea to test fit each part before assembly. Fiberglass parts still contain small amounts of mold release and other materials on the surface that will inhibit adhesives and/or paint. It is important to clean each part prior to assembly with a solution of 1 part rubbing alcohol, 3 parts water and a drop of dish washing soap. **IMPORTANT:** do not sand any parts until after you have cleaned them - you will embed the materials you are trying to clean making it difficult to clean.

The G10 parts will have holding tabs left over from the CNC machine. These small tabs will need to be sanded off before assembly. Before assembling any part with epoxy, rough up the surface to be epoxied using course sandpaper. The scratches in the G10 surface will give the epoxy something to grab onto.

Step 1 – Motor Mount Assembly

Test fit the centering rings over the motor mount tube and sand if necessary. Also test fit the centering rings in the body tube and sand if necessary. The ring with the 1/4" hole for an eyebolt will be the forward ring. Spread some epoxy on the outside of one end of the motor tube and slide the ring (without the hole) until there is approximately 1/2" of motor tube exposed. Make sure you clean the motor tube of any epoxy so as not to interfere with the fin tangs later. After the aft ring is dry, make a mark 1" from the other end of the motor tube. Spread some epoxy on the motor tube and slide the forward ring until it aligns with the mark. **VERY IMPORTANT: make sure there is not any epoxy on the motor tube that would interfere with the fin tangs later on. Also test fit one of the fins to make sure there is enough room for the fin tang between the centering rings.**

Mount the eyebolt using the two nuts as shown in the forward ring hole. Apply some epoxy to the nuts to ensure they will not come loose later. Attach one end of the shock cord to the eyebolt using an overhand knot. **IMPORTANT: Make sure the eyebolt and nut are aligned properly so the motor assembly can slide into the body tube.**

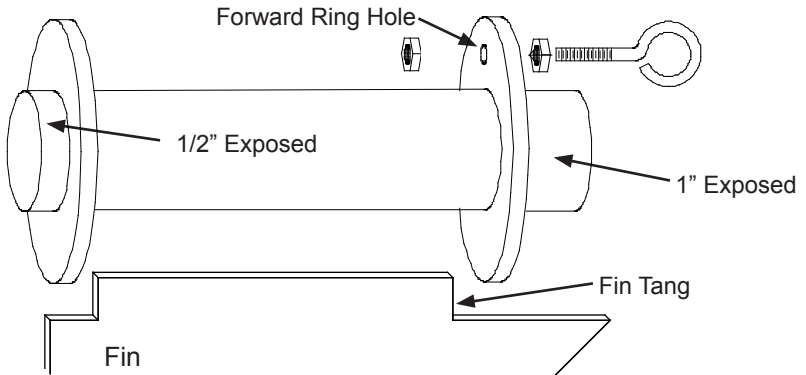

Step 2 – Insert Motor Tube Assembly into Body Tube

Wrap the shock chord into a small bundle and stuff it inside the motor tube for this next step. Test fit the motor tube assembly into the body tube to ensure a snug fit. Sand the centering rings if necessary. When you are satisfied with the fit, spread some epoxy on the inside of the body tube and slide the forward centering ring of the motor assembly into the body tube. **Make sure you have the motor assembly facing the right way!** Spread some more epoxy on the inside edge of the body tube before sliding the rear centering ring into the body tube. Continue sliding the assembly inside the body tube until the aft end of the motor tube is even with the aft end of the body tube. It's a good

idea to test fit a fin in each slot here before the epoxy sets. Hold the body tube with the motor tube assembly down until the epoxy sets. Make sure the weight of the motor assembly doesn't cause it to slide out of alignment.

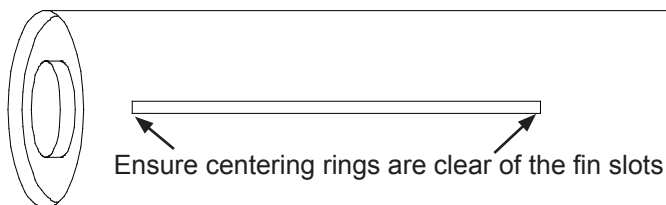

Step 3 – Fin Assembly

Using a door jam or small section of angle stock, pencil a line halfway between two of the fins that extends from the front to the back of the body tube. This line will be used later to align the launch lugs.

Test fit each of the fins into the pre cut fin slots. The fin should seat firmly against the motor tube - sand each fin if necessary. The fin tang is intentionally a little long to ensure the fin tang will contact the motor tube. You can shorten the fin tang a little bit at a time until the root of the fin seats against the body tube. Make sure you don't shorten the fin tang too much because it is important the fin tang has a good bond with the motor tube. If there is a gap remaining between the root and body tube, you can fill with the fin fillets later in this step. When you are satisfied with the fit, apply some epoxy to the end of the fin tang that will contact the motor tube. Also, spread a thin layer of epoxy on each side of the fin tang. Slide the fin into place and check the alignment. Continue rechecking the fin alignment until you are sure the epoxy has set. Clean any excess epoxy from around the fin joint. Repeat for the remaining fins. Next, apply epoxy fillets to both sides of each fin. Carefully smooth the epoxy fillets with your finger before the epoxy sets. Allow each fillet to set before rotating the airframe for the next fillet.

Step 4 – Launch Lug Attachment

Apply a small amount of epoxy on the shorter edge of the launch lug spacers. Press the launch lugs onto the end of the launch lug spacers as shown in the figure. Apply a small amount of epoxy on the long edge of one of the launch lug assemblies. Press the assembly along the launch lug line on the body tube about $\frac{1}{2}$ " from the aft end of the body tube. Ensure that it is aligned with the launch lug line previously drawn on the body tube. You can sit down the tube and look through the launch lug to make sure it is straight. Similarly epoxy the second launch lug assembly 3" from the forward end of the body tube. Site down both launch lugs and make sure they are both aligned. If you have a $\frac{1}{4}$ " launch rod, you can use this to ensure that both lugs are aligned properly.

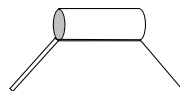

Step – Nose Cone Assembly

Mount the remaining eyebolt using the nuts and washer in the nose cone bulkplate. Apply some epoxy to the nut so it will not come loose later. Test fit the bulkplate in the base of the nose cone and sand if necessary. At this point, pack the chute and assemble the rocket. Insert the largest motor that you intend to fly (or simulate the weight with an appropriate substitute) and ensure that the CG is forward of the point defined in the specifications on the first page. The CG should be measured from the tip of the nose cone. If the CG is behind the specified point, add weight inside the nose cone and secure with epoxy. When you are satisfied with the CG, epoxy the bulkplate into the base of the nose cone leaving at least a $\frac{1}{4}$ " lip to apply a fillet. Next, apply a fillet of epoxy around the bulkplate and nose cone shoulder joint.

When the nose cone assembly is dry, it is time to attach the spin motor façades. The four motors are attached at 90 degree intervals around the transition section of the nose cone. The base of the motor is 7/8" above the base of the nose cone and the left edge of the motor should be parallel to the centerline of the nose cone.

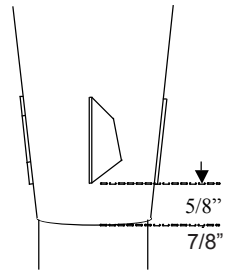

Your model is now ready to paint and apply the decal. To apply the cut lettering decal, carefully remove the backing from the decal - the individual letters will remain stuck to the top carrier. Next, position the decal where you would like it and carefully smooth out the top carrier to ensure the letters are securely attached to the rocket body. Last, carefully remove the top carrier making sure the letters stay attached to the rocket body and are not lifted with the carrier.

Step 7 – Flying Your Model

Attach the end of the shock cord and the parachute to the eyebolt. You can also attach the chute protector to the shock cord just below the nose cone. When packing your chute, wrap the chute protector around the chute with the opening in the chute protector facing forward. Always make sure your chute is well protected as the hot ejection motor gasses will melt the nylon chute.

IMPORTANT: always use positive motor retention to secure the motor in the motor tube. Failure to use motor retention may allow the motor to be ejected during the ejection charge instead of the parachute, making for a dangerous ballistic reentry.

IMPORTANT: always remember to check your balance point and ensure your CG is forward of the recommended CG point.

IMPORTANT: Always follow the NAR safety code and remember that rockets are not toys and can be dangerous if not prepared and used properly. If you are a beginner, it is a good idea to fly with a club or other group of experienced rocketeers until you have gained some experience.

IMPORTANT: In no event shall Madcow Rocketry be liable for any direct, indirect, punitive, incidental, special consequential damages whatsoever arising out of or connected with the use or misuse of it's products. The buyer assumes all risk and liability resulting from ANY use of any and all products sold by Madcow Rocketry. Your purchase and use of any Madcow Rocketry product constitutes your agreement to and acceptance of these terms. If you do not agree to these terms and conditions, you must return the unused product in resalable condition for a refund or credit.

IMPORTANT: Please contact us via phone or email if you have any questions about constructing or flying your model.



24338 El Toro Rd #E-134
Laguna Woods, CA 92637
949.547.8847
www.madcowrocketry.com
©2006 MadCow Rocketry™