

Motor Mount

- 54mm
- 75mm
- Dual Deploy



super™ DX3

ALL FIBERGLASS KIT

Specifications

Length: 66.5"
Diameter 4.0"
Weight: 6lbs
Motor Mount: 54mm or 75mm
Fins: 3 - 1/8" G10
Estimated CP: 48" from nose tip
75MM Version Dual Deploy Ready

Parts List

- | | |
|-----------------------------|-----------------------------------|
| (1) Nose Cone | 75MM Also Includes: |
| (1) Pre-slotted body tube | (1) Centering ring |
| (1) Forward body tube | |
| (1) Coupler | Dual Deploy Also Includes: |
| (1) Bulkhead | (3) Bulkheads |
| (2) Centering rings | (2) Eyebolts |
| (1) Motor tube | (8) Nuts |
| (3) G10 fins | (8) Washers |
| (2) Eyebolts | (2) Threaded Rods |
| (2) Nuts | |
| (2) Washers | |
| (1) Nylon shock cord | |
| (2) Rail buttons and screws | |

You'll need these items to complete this kit

- 5 Minute Epoxy
- Filler and Paint
- Zap or CA Super Glue
- Motor Retainer
- Pencil
- 120/220 Sandpaper

K-159

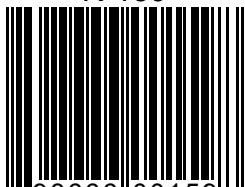

8 98666 00159 8

madcow Rocketry®
put some fun in your rockets!

Please make sure you read all directions and understand how to assemble your model before you start construction. It is also a good idea to test fit each part before assembly.

Fiberglass parts still contain small amounts of mold release and other materials on the surface that will inhibit adhesives and/or paint. It is important to clean each part prior to assembly with a solution of 1 part rubbing alcohol, 3 parts water and a drop of dish washing soap. **IMPORTANT:** do not sand any parts until after you have cleaned them - you will embed the materials you are trying to clean making it difficult to clean.

Some G10 parts may have holding tabs left over from the CNC machine. These small tabs will need to be sanded off before assembly.

IMPORTANT: Before assembling any part with epoxy, rough up the surface to be epoxied using 60-80 sandpaper. The scratches in the fiberglass surface will give the epoxy something to grab onto. Epoxy will not soak into the fiberglass like wood or cardboard - epoxy will not grip very well to fiberglass without this rough surface. You can use Zap or CA glue to tack parts into place before you apply epoxy.

Motor Mount Assembly

- Step 1 - Rough the surface of the motor tube where the centering rings will contact it - also rough the surface where the fin tangs will contact the motor tube.
- Step 2 - Test fit the centering rings over the motor mount tube and sand if necessary. Also test fit the centering rings in the body tube and sand if necessary.
- Step 3 - Mark the motor tube 3/4" from the aft end of the motor tube. Spread some epoxy on the motor tube around the mark and slide the aft centering ring on the tube until it aligns with the mark. For the 75mm version, the middle centering ring can go just forward of the fin tangs.
- Step 4 - For the 54mm version, drill a 1/4" hole in the forward centering ring for the eyebolt. Both versions, mark the motor tube 1" from the front of the motor tube. Spread some epoxy around the mark and slide the centering ring on the motor tube until it aligns with the mark.
- Step 5 - For 75mm version, you must use a threaded forward motor closure for shock cord attachment. For 54mm version, mount the eyebolt using the nut and washer in the forward ring hole. Apply some epoxy to the threads of the eyebolt and nut to ensure it will not come loose later. Make sure the eyebolt is aligned so that it will not interfere with the body tube when the motor assembly is inserted into the body tube later.

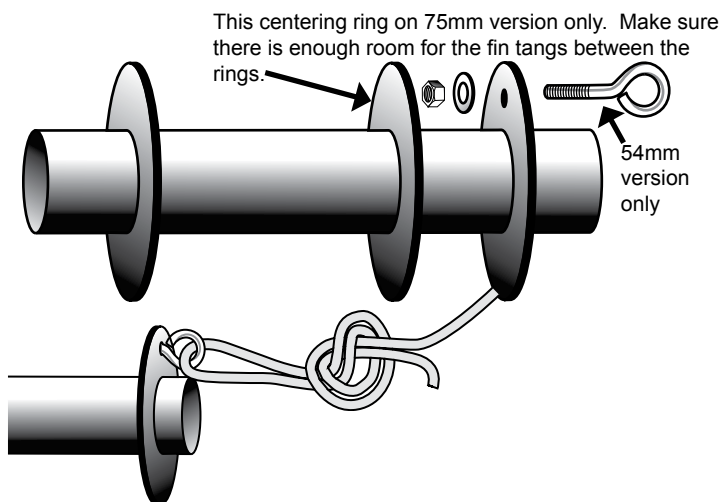

- Step 6 - For 54mm version, attach one end of the shock cord to the eyebolt using an overhand knot as shown. Set this assembly aside for later.

Body Tube Assembly

- Step 7 - Using the motor tube assembly, wrap the shock chord into a small bundle and stuff it inside the motor tube for this next step. Test fit the motor tube assembly into the aft end of the body tube to ensure a snug fit. Sand the centering rings if necessary. Make sure you rough up the inside of the body tube where the centering rings will attach.
- Step 8 - When you are satisfied with the fit, spread some epoxy on the inside of the body tube just in front of the fin slots and slide the forward centering ring of the motor assembly into the body tube. **Make sure you have the motor assembly facing the right way - the centering ring with the eyebolt should slide in first!**

Keep going by spreading some more epoxy on the inside of the body tube near the aft edge before sliding the aft centering ring into the body tube. Continue sliding the assembly inside the body tube until the aft centering ring is all the way in body tube, but doesn't yet interfere with the fin slot. It's a good idea to test fit a fin in each slot here before the epoxy sets. Hold the body tube with the motor tube assembly down until the epoxy sets. Make sure the weight of the motor assembly doesn't cause it to slide out of alignment.

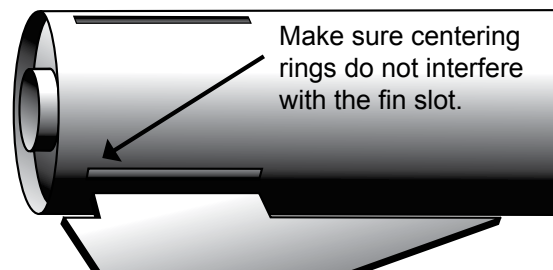

Fin Assembly

- Step 9 - Test fit each of the fins into the pre cut fin slots. The fin should seat firmly against the motor tube - sand each fin if necessary. Don't forget to rough up all surfaces. When you are satisfied with the fit, apply some epoxy to the end of the fin tang that will contact the motor tube as well as any fin root that will contact the body tube. Also, spread a thin layer of epoxy on each side of the fin tang. Slide the fin into place and check the alignment. Continue rechecking the fin alignment until you are sure the epoxy has set. Clean any excess epoxy from around the fin joint. Repeat for the remaining fins.
- Step 10 - Next, apply epoxy fillets to both sides of each fin. Carefully smooth the epoxy fillets with your finger before the epoxy sets. Allow each fillet to set before rotating the airframe for the next fillet.

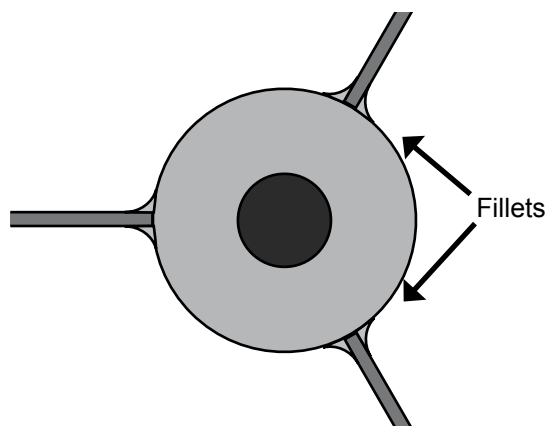

Rail Button Attachment

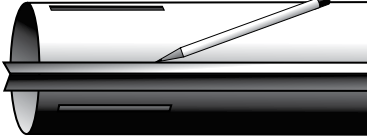
- Step 11 - Using a door jam or small section of angle stock, pencil a line halfway between two of the fins on the main body tube that extends from the front to the back of the body tube. 
- Step 12 - Drill a 5/64" hole on the rail button line for the forward and aft rail buttons. The aft hole should be 1 1/2" from the aft end of the body tube and the forward hole should be 7" from the forward end of the body tube.
- Step 13 - Apply a small amount of epoxy in the holes and attach the rail buttons using the supplied #6 wood screws. Make sure the screw is loose enough for the rail button to spin freely - this ensures the button is not compressed to the point it will hang on the rail guide.

IMPORTANT: Make sure the forward rail button screw protruding through the body tube doesn't snag the chute. Epoxy over the screw to provide a smooth surface.

Payload Section Assembly - Non Dual Deploy

(Skip Steps 14-16 for Single Deploy Version)

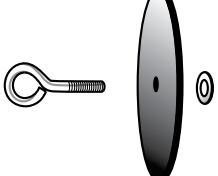
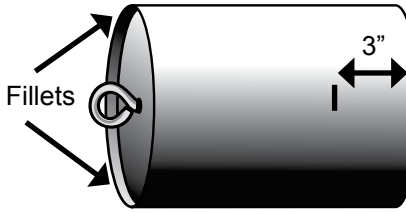
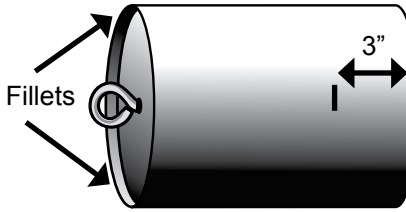
- Step 14 - Insert the eyebolt through the hole in the center of the bulkhead and secure using the washer and nut. **IMPORTANT: Apply some epoxy to the nut and eyebolt threads to ensure the nut doesn't come loose later.** 
- Step 15 - Apply some epoxy to the inside of the coupler and push the bulkhead in so there is about a 1/8" to 1/4" of coupler exposed. After the epoxy has set, apply a fillet of epoxy around the inside edge of the coupler bulkhead joint. 
- Step 16 - Next mark the coupler 3" from the forward edge. Apply some epoxy to the inside of the forward body tube section and slide the coupler up to the mark. There should be 5" of coupler exposed. Make sure the coupler is straight and the body tubes are aligned properly when they are assembled later. 

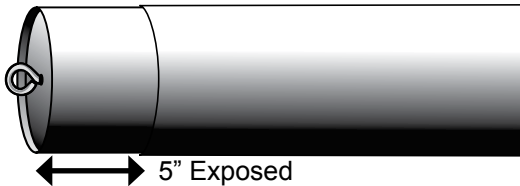

Payload Section Assembly - Dual Deploy Only

(Skip Steps 17-24 for non-Dual Deploy Version)

- Step 17 - Mark and drill 2 of the larger bulkheads and 1 smaller bulkhead with 2 additional 1/4" holes as shown in the Dual Deploy version payload section assembly diagram. These holes are 2" apart or 1" from the center hole.
- Step 18 - Start with one of the larger bulkheads and attach the eyebolt and two threaded rods as shown in the diagram above. Use two washers and two nuts on each threaded rod to trap the bulkhead. Most of the threaded rod should extend into the coupler. Leave about 1/4" of exposed threaded rod that extends forward. Use thread lock on all nuts to make sure they doesn't come loose later.
- Step 19 - Tack the forward bulkhead you just worked on to one end of the coupler with epoxy or CA glue. Be very careful that the bulkhead is aligned and flush with the outside of the coupler so that it will slide into the airframe later. Also make sure there is no glue on the outside of the coupler or bulkhead that would interfere with inserting into the airframe.
- Step 20 - Carefully align the three holes in the remaining large bulkhead and the one of the remaining small bulkheads and attach them together using the remaining eyebolt (the last small bulkhead is for the nose cone later). Use thread lock to make sure the eyebolt doesn't come loose later. The smaller bulkhead will go into the coupler first. **IMPORTANT: do not glue the bulkheads into the coupler - they need to be removed to insert the altimeter.** Insert onto the open end of the coupler and attach with the remaining washers and nuts. **IMPORTANT: do not use thread lock on these nuts so they can be removed later.**
- Step 21 - Using the same knot you used in step 6, attach the other end of the shock cord to the forward eyebolt of the coupler assembly before epoxying it into payload section in the next step.
- Step 22 - Apply epoxy to the inside of the forward airframe and insert the coupler assembly until there is 5" exposed (3" will be inserted into the airframe). **IMPORTANT: make sure you insert the right end.** The removable bulkheads should be outside the airframe.
- Step 23 - Mount the remaining eyebolt using the nut and washer in the nose cone bulkplate. Apply some epoxy to the nut so it will not come loose later. Test fit the bulkplate in the base of the nose cone and sand if necessary.
- Step 24 - Epoxy the bulkplate into the base of the nose cone leaving at least a 1/4" lip to apply a fillet. Next, apply a fillet of epoxy around the bulkplate and nose cone shoulder joint.

Payload Section Assembly Diagram - Dual Deploy Version

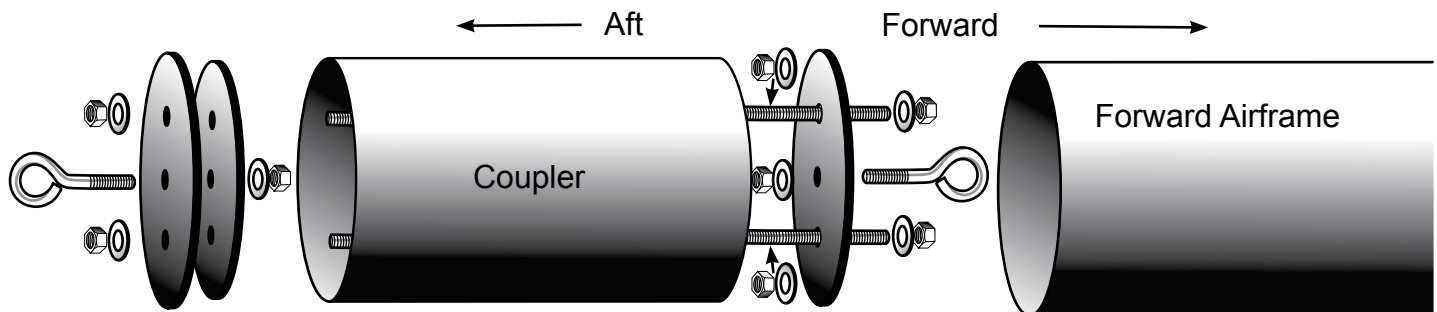

Final Assembly

- Step 25 - Using the same knot you used in step 6, attach the other end of the shock cord to the payload section eyebolt. Attach the parachute to the shock cord near the payload section. Also attach the chute protector to the shock cord near the payload section.
- Step 26 - Drill a small 1/8" hole in the chute compartment(s) to allow venting. Make sure you do this without the chute in the chute compartment.
- Step 27 - At this point install your positive motor retention device. The kit does not include a motor retention device and this will need to be purchased separately.

Balancing Your Model

- Step 28 - Pack the chute and assemble the rocket. Insert the largest motor that you intend to fly (or simulate the weight with an appropriate substitute) and ensure that the CG is at least 1 body diameter in front of the estimated CP point specification on the first page. The estimated CP should be measured from the tip of the nose cone. If the CG is too far back, add weight inside the nose cone by pouring lead shot into the nose cone and adding some epoxy.
- Step 29 - Your model is now ready to paint and apply the decals. To apply the cut lettering decal, carefully remove the backing from the decal - the individual letters will remain stuck to the top carrier. Next, position the decal where you would like it and carefully smooth out the top carrier to ensure the letters are securely attached to the rocket body. Last, carefully remove the top carrier making sure the letters stay attached to the rocket body and are not lifted with the carrier.

At this point your model is ready to fly.
Now go have some fun!

Flying Your Model

IMPORTANT: always use positive motor retention to secure the motor. Failure to use motor retention will cause the motor to be ejected instead of the parachute making for a dangerous ballistic reentry.

IMPORTANT: always remember to check your balance point and ensure your CG is forward of the specified CG point.

IMPORTANT: Always follow the NAR safety code and remember that rockets are not toys and can be dangerous if not prepared and used properly. If you are a beginner, it is a good idea to fly with a club or other group of experienced rocketeers until you have gained some experience.

IMPORTANT: In no event shall Madcow Rocketry be liable for any direct, indirect, punitive, incidental, special consequential damages whatsoever arising out of or connected with the use or misuse of its products. The buyer assumes all risk and liability resulting from ANY use of any and all products sold by Madcow Rocketry. Your purchase and use of any Madcow Rocketry product constitutes your agreement to and acceptance of these terms. If you do not agree to these terms and conditions, you must return the unused product in resaleable condition for a refund or credit.

IMPORTANT: Please contact us via phone or email if you have any questions about constructing or flying your model.



24338 El Toro Rd #E-134

Laguna Woods, CA 92637

949.547.8847

www.madcowrocketry.com

support@madcowrocketry.com

©2009 MadCow Rocketry™