



U.S. ARMY MIM-23B HAWK

Specifications:

Length: 36.25"
Diameter 2.6"
Weight: 40oz
Recovery: 36" Nylon Chute
Motor Mount: 38mm
Fins: 4 - 1/16" G10
Recommended CG: 22.5"

Suggested Motors:

<i>Aerotech</i>	<i>Cesaroni</i>
G67R-6 790'	G115WT-8 1000'
H148R-10 1850'	H143SS-10 2100'
H242T-10 2150'	H225WT-11 2490'

Parts List

1. (1) Fiberglass nose cone
2. (1) G10 nose cone bulk plate
3. (1) Pre-slotted body tube
4. (2) G10 centering rings
5. (1) 38mm motor tube
6. (4) G10 fins
7. (2) Eyebolt, nut, washer set
8. (1) Nylon shock cord
9. (2) Rail Buttons and Screws
10. (1) Cut Letter Vinyl decal
11. (1) Fiberglass Tailcone

Optional Recovery System

1. (1) 9"x9" flameproof chute protector
2. (1) 36" Nylon chute

Required to complete: 5 minute epoxy, 120/220 sandpaper, masking tape, finishing filler/paint, Rubbing Alcohol for cleaning.

K-151



8 98666 00151 2



Please make sure you read all directions and understand how to assemble your model before you start construction. It is also a good idea to test fit each part before assembly. Fiberglass parts still contain small amounts of mold release and other materials on the surface that will inhibit adhesives and/or paint. It is important to clean each part prior to assembly with a solution of 1 part rubbing alcohol, 3 parts water and a drop of dish washing soap. **IMPORTANT:** do not sand any parts until after you have cleaned them - you will embed the materials you are trying to clean making it difficult to clean.

The G10 parts will have holding tabs left over from the CNC machine. These small tabs will need to be sanded off before assembly. Before assembling any part with epoxy, rough up the surface to be epoxied using course sandpaper. The scratches in the G10 surface will give the epoxy something to grab onto.

Step 1 – Motor Mount Assembly

Test fit the centering rings over the motor mount tube and sand if necessary. Also test fit the centering rings in the body tube and sand if necessary. The ring with the 1/4" hole for an eyebolt will be the forward ring. Spread some epoxy on the outside of one end of the motor tube and slide the ring (without the hole) until there is approximately 3 1/4" of motor tube exposed. Make sure you clean the motor tube of any epoxy so as not to interfere with the fin tangs later. After the aft ring is dry, make a mark 1/2" from the other end of the motor tube. Spread some epoxy on the motor tube and slide the forward ring until it aligns with the mark. **VERY IMPORTANT: make sure there is not any epoxy on the motor tube that would interfere with the fin tangs later on. Also test fit one of the fins to make sure there is enough room for the fin tang between the centering rings.**

Mount the eyebolt using the two nuts as shown in the forward ring hole. Apply some epoxy to the nuts to ensure they will not come loose later. Attach one end of the shock cord to the eyebolt using an overhand knot. **IMPORTANT: Make sure the eyebolt and nut are aligned properly so the motor assembly can slide into the body tube.**

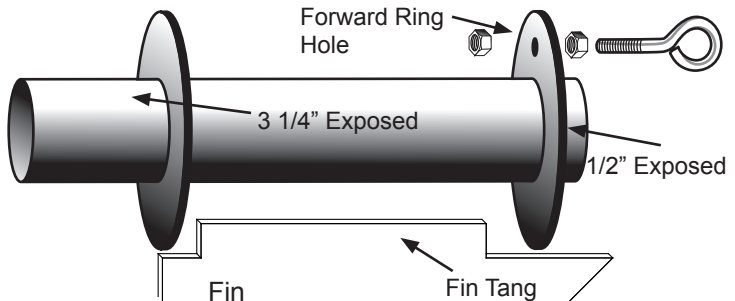

Step 2 – Insert Motor Tube Assembly into Body Tube

Wrap the shock chord into a small bundle and stuff it inside the motor tube for this next step. Test fit the motor tube assembly into the body tube to ensure a snug fit. Sand the centering rings if necessary. **Before you glue: test fit the tail cone and make sure the aft centering ring is far enough in the body tube so the shoulder of the tail cone can slide all the way into the body tube. ALSO, make sure the fin slots are clear by test fitting a fin in each slot. The aft centering ring should find a place in between the tail cone shoulder and the fin tang. Ideally, the aft end of the motor tube should be flush with the aft end of the tail cone to allow easy retainer attachment.**

When you are satisfied with the fit, spread some epoxy on the inside of the body tube and slide the forward centering ring of the motor assembly into the body tube. **Make sure you have the motor assembly facing the right way!** Spread some more epoxy on the inside edge of the body tube before sliding the rear centering ring into the body tube. Continue sliding the assembly inside the body tube until the aft centering ring fits between the tailcone and the fin tang as you tested before. It is a good idea to test the position again with a fin and the tailcone before the epoxy sets. When the motor tube epoxy has set, epoxy the tailcone in place.

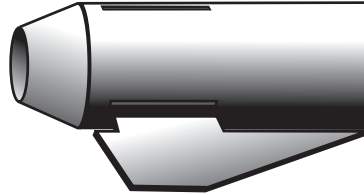

Step 3 – Fin Assembly

Using a door jam or small section of angle stock, pencil a line halfway between two of the fins that extends from the front to the back of the body tube. This line will be used later to align the rail buttons. Using the same method, pencil a line that extends from each of the fin slots to the forward end of the body tube. This will help you align the long forward section of the fins.

Test fit each of the fins into the pre cut fin slots. The fin should seat firmly against the motor tube - sand each fin if necessary. When you are satisfied with the fit, apply some epoxy to the end of the fin tang that will contact the motor tube as well as the fin root that will contact the body tube. Also, spread a thin layer of epoxy on each side of the fin tang.

Slide the fin into place and check the alignment. Carefully align the long forward section of the fin with your fin alignment marks. Secure the forward section of the fin with masking tape against the body tube. Clean any excess epoxy from around the fin joint. Continue rechecking the fin alignment until you are sure the epoxy has set. Repeat for the remaining fins. Note: When assembling a 4 fin rocket, sometimes it is easier to assemble the 2 opposing fins at the same time. Make sure both fins form a straight line when viewed from the rear of the rocket. A straight edge held on the aft end of the rocket can help with this alignment.

Next, apply epoxy fillets to both sides of each fin. Carefully smooth the epoxy fillets with your finger before the epoxy sets. Allow each fillet to set before rotating the airframe for the next fillet.

Step 4 – Rail Button Attachment

Mark the CG point along the rail button line you made in the previous step. Make sure you measure the CG point from the tip of the nose cone and NOT the end of the body tube. Drill a 5/64" hole on the rail button line for the forward and aft rail buttons. The aft hole should be 1/2" from the aft end of the body tube and the forward hole should be at the CG point. Apply a small amount of epoxy in the holes and attach the rail buttons using the supplied #6 wood screws. Make sure the screw is loose enough for the rail button to spin freely - this ensures the button is not compressed to the point it will hang on the rail guide.

IMPORTANT: Make sure the forward rail button screw protruding through the body tube doesn't snag the chute. Epoxy over the screw to provide a smooth surface. The screw can also be cut shorter.

Step 5 – Balance and Nose Cone Assembly

Mount the remaining eyebolt using the nuts and washer in the nose cone bulkplate. Apply some epoxy to the nut so it will not come loose later. Test fit the bulkplate in the base of the nose cone and sand if necessary. At this point, pack the chute and assemble the rocket. Insert the largest motor that you intend to fly (or simulate the weight with an appropriate substitute) and ensure that the CG is forward of the recommended CG in the specifications on the first page. The CG should be measured from the tip of the nose cone. If the CG is aft of the recommended point, add weight inside the nose cone and secure with epoxy until the CG is at or in front of the recommended point. When you are satisfied with the CG, epoxy the bulkplate into the base of the nose cone leaving at least a 1/4" lip to apply a fillet. Next, apply a fillet of epoxy around the bulkplate and nose cone shoulder joint.

Step 6 – Flying Your Model

Attach the end of the shock cord and the parachute to the nose cone eyebolt. You can also attach the chute protector to the shock cord just below the nose cone. When packing your chute, wrap the chute protector around the chute with the opening in the chute protector facing forward. Always make sure your chute is well protected as the hot ejection motor gasses will melt the nylon chute.

IMPORTANT: always use positive motor retention to secure the motor in the motor tube. Failure to use motor retention may allow the motor to be ejected during the ejection charge instead of the parachute, making for a dangerous ballistic reentry.

IMPORTANT: always remember to check your balance point and ensure your CG is forward of the recommended CG point.

IMPORTANT: Always follow the NAR safety code and remember that rockets are not toys and can be dangerous if not prepared and used properly. If you are a beginner, it is a good idea to fly with a club or other group of experienced rocketeers until you have gained some experience.

IMPORTANT: In no event shall Madcow Rocketry be liable for any direct, indirect, punitive, incidental, special consequential damages whatsoever arising out of or connected with the use or misuse of its products. The buyer assumes all risk and liability resulting from ANY use of any and all products sold by Madcow Rocketry. Your purchase and use of any Madcow Rocketry product constitutes your agreement to and acceptance of these terms. If you do not agree to these terms and conditions, you must return the unused product in resalable condition for a refund or credit.

IMPORTANT: Please contact us via phone or email if you have any questions about constructing or flying your model.



24338 El Toro Rd #E-134
Laguna Woods, CA 92637
949.547.8847
www.madcowrocketry.com
©2006 MadCow Rocketry™